



# kolin

# QUAD

# Ai

*Full DC Inverter Window Type Air Conditioner*

## OWNER'S MANUAL

**MODEL:**

**KA-75GQAIINV32**

**KA-100GQAIINV32**

**KA-150GQAIINV32**

**KA-200GQAIINV32**

**KA-250GQAIINV32**

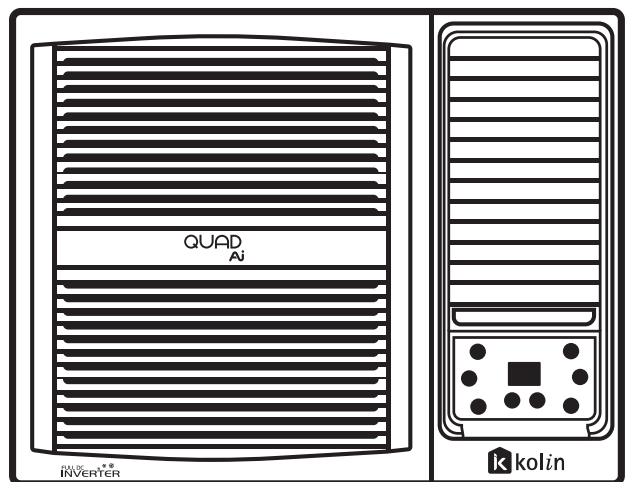

Thank you for purchasing our air conditioner. Please read this manual carefully before operating your new air conditioning unit. Make sure to save this manual for your reference.



 Kolin Philippines International, Inc.



# TABLE OF CONTENTS

<b>SAFETY PRECAUTIONS.....</b>	<b>2</b>
<b>SAFETY MANUAL</b>	
• The Refrigerant.....	5
• Safety Operation of Flammable Refrigerant.....	6
• Specialist Manual.....	8
<b>INTRODUCTION AND PARTS IDENTIFICATION.....</b>	<b>12</b>
<b>INSTALLATION.....</b>	<b>14</b>
<b>OPERATION MANUAL</b>	
• Control Panel.....	18
• Remote Operations.....	20
◦ Buttons and Functions.....	20
◦ Remote Screen Display Indicators.....	21
◦ How to Use Basic Functions.....	22
◦ Remote - Care and Maintenance.....	27
◦ Remote - Troubleshooting.....	28
• Operation Tips.....	29
<b>CARE AND MAINTENANCE.....</b>	<b>30</b>
<b>TROUBLESHOOTING.....</b>	<b>31</b>

# SAFETY PRECAUTIONS

## Read Safety Precautions Before Operation and Installation

Incorrect installation due to ignored instructions may cause serious damage or injury.

The seriousness of potential damage or injury is classified as either a **WARNING** or **CAUTION**.



### WARNING

This symbol indicates a potential risk of personal injury or loss of life.



### CAUTION

This symbol indicates a potential risk of property damage or serious consequences.



### WARNING

This appliance can be used by children aged 8 years and older, as well as individuals with reduced physical, sensory, or mental abilities, or those lacking experience and knowledge, provided they have received supervision or instruction on how to use the appliance safely and understand the potential hazards. Children must not play with the appliance. Cleaning and maintenance should not be performed by children without supervision.

This appliance is not intended for use by persons (including children) with reduced physical, sensory, or mental capabilities, or those lacking experience and knowledge, unless they have received proper supervision or instruction from a responsible individual. Children should be supervised to prevent them from playing with the appliance.



### WARNINGS FOR PRODUCT USE

- Turn off the air conditioner and disconnect the power before performing any cleaning, installation, or repairs. Failure to do so can cause an electric shock.
- If an abnormal situation arises (such as a burning smell), immediately turn off the unit and disconnect the power. Contact Kolin Service Hotline for further instructions to avoid electric shock, fire, or injury.
- **DO NOT** insert fingers, rods, or other objects into the air inlet or outlet. This may cause injury, as the fan may be rotating at high speeds.
- **DO NOT** use flammable sprays such as hair spray, lacquer or paint near the unit. These substances can cause fire or combustion.
- **DO NOT** operate the air conditioner in places near or around combustible gases. Emitted gas may collect around the unit, which could lead to an explosion.
- **DO NOT** operate the air conditioner in wet environments, such as bathrooms or laundry rooms. Excessive exposure to water may cause electrical components to short-circuit.
- **DO NOT** expose your body directly to cool air for a prolonged period of time.
- **DO NOT** allow children to play with the air conditioner. Children must be supervised around the unit at all times.
- If the air conditioner is used together with burners or other heating devices, ensure proper ventilation in the room to avoid oxygen deficiency.
- In certain functional environments, such as kitchens, server rooms, etc., the use of specially designed air-conditioning units is highly recommended.



### CLEANING AND MAINTENANCE WARNINGS

- Turn off the air conditioner and disconnect the power before cleaning. Failure to do so can cause electric shock.
- **DO NOT** clean the air conditioner with excessive amounts of water.
- **DO NOT** clean the air conditioner with combustible and harmful cleaning agents. These may cause fire, deformation or corrosion to the unit.



### CAUTION

- Turn off the air conditioner and disconnect the power if you are not going to use it for a long time.
- Turn off and unplug the unit during storms.
- Make sure that water condensation can drain unhindered from the unit.
- **DO NOT** use device for any other purpose than its intended use.
- **DO NOT** climb onto or place objects on top of the outdoor unit.
- **DO NOT** operate the air conditioner with wet hands. This may cause electric shock.
- **DO NOT** allow the air conditioner to operate for long periods of time with doors or windows open, or if the humidity is very high.



### ELECTRICAL WARNINGS

- Use only the specified power cord. If it's damaged, contact Kolin Service Hotline or its Authorized Service Partners for replacement to avoid hazards.
- Keep power plug clean. Remove any dust or grime that accumulates on or around the plug. Dirty plugs can cause fire or electric shock.
- The product must be properly grounded during installation to avoid electric shock.
- **DO NOT** pull power cord to unplug unit. Hold the plug firmly and pull it from the outlet. Pulling directly on the cord can damage it, which can lead to fire or electric shock.
- **DO NOT** modify the length of the power supply cord or use an extension cord to power the unit.
- **DO NOT** share the electrical outlet with other appliances. Improper or insufficient power supply can cause fire or electrical shock.
- For all electrical work, follow all local and national wiring standards, regulations, and the Installation Manual. Connect cables tightly, and clamp them securely to prevent external forces from damaging the terminal. Improper electrical connections can overheat and cause fire, and may also cause shock.
- Model and rated value of fuse shall be subject to screen print on corresponding controller or protective brushing.
- Please install the devices for short-circuit protection and electrical leakage protection when installing the air conditioner.
- According to the local safety regulations, use qualified power supply circuit and circuit break.

Standard Circuit Breaker Ampere Ratings and Equivalent Stranded Wire Sizes for Air Conditioners

MODEL	Wire Type	Equivalent Stranded Wire Size (mm <sup>2</sup> )	Ampere Rating
KA-75GQAIINV32 KA-100GQAIINV32 KA-150GQAIINV32	THHN/ THWN	2.0 mm <sup>2</sup>	15A
KA-200GQAIINV32 KA-250GQAIINV32	THHN/ THWN	3.5 mm <sup>2</sup>	20A



## WARNINGS FOR PRODUCT INSTALLATION

- Installation must be performed by Kolin Authorized Technicians or its Authorized Service Partners. Defective installation can cause water leakage, electrical shock, or fire.
- Installation must be performed according to the installation instructions. Improper installation can cause water leakage, electrical shock, or fire.
- Contact Kolin Service Hotline or its Authorized Service Partners for repair or maintenance of this unit.
- This appliance shall be installed in accordance with national wiring regulations.
- Only use the included accessories, parts, and specified parts for installation. Using non-standard parts can cause water leakage, electrical shock, fire, and can cause the unit to fail.
- Install the unit in a firm location that can support the unit's weight. If the chosen location cannot support the unit's weight, or the installation is not done properly, the unit may drop and cause serious injury and damage.
- Install drainage piping according to the instructions in this manual. Improper drainage may cause water damage to your home and property
- For units that have an auxiliary electric heater, **DO NOT** install the unit within 1 meter (3 feet) of any combustible materials.
- **DO NOT** install the unit in a location that may be exposed to combustible gas leaks. If combustible gas accumulates around the unit, it may cause fire.
- **DO NOT** turn on the power until all work has been completed.
- When moving or relocating the air conditioner, consult and contact Kolin Service Hotline or its Authorized Service Partners for disconnection and reinstallation of the unit.
- How to install the appliance to its support, please read the information for details in "indoor unit installation" and "outdoor unit installation" sections .

## European Disposal Guidelines

This marking shown on the product or its literature, indicates that waste electrical and electrical equipment should not be mixed with general household waste.

*Correct Disposal of This Product  
(Waste Electrical & Electronic Equipment)*

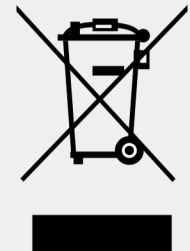

This appliance contains refrigerant and other potentially hazardous materials. When disposing of this appliance, the law requires special collection and treatment. **DO NOT** dispose of this product as household waste or unsorted municipal waste.

When disposing of this appliance, you have the following options:

- Dispose of the appliance at designated municipal electronic waste collection facility.
- When buying a new appliance, the retailer will take back the old appliance free of charge.
- The manufacturer will take back the old appliance free of charge.
- Sell the appliance to certified scrap metal dealers.

### SPECIAL NOTICE

Disposing of this appliance in the forest or other natural surroundings endangers your health and is bad for the environment. Hazardous substances may leak into the ground water and enter the food chain.



Appliance filled with flammable gas R32 refrigerant.



Before using the appliance, read the owner's manual first.



Before installing the appliance, read the installation manual first.



Before repairing the appliance, read the service manual first.

## THE REFRIGERANT

- To enable the proper functioning of the air conditioner unit, a special refrigerant circulates within the system. The refrigerant used is R32 fluoride, which undergoes special purification. R32 is a flammable and odorless refrigerant. Under certain conditions, it may lead to an explosion. However, its flammability is very low and can only be ignited by an open flame.
- Compared to common refrigerants, R32 is an environmentally friendly option that does not harm the ozone layer. It also has a lower impact on the greenhouse effect. Additionally, R32 has excellent thermodynamic properties, resulting in high energy efficiency. As a result, the units require a smaller refrigerant charge.

### **Warning**

- Do not use any method to accelerate the defrosting process or to clean the appliance other than those recommended by the manufacturer. If repairs are needed, contact Kolin-service hotline or its Authorized Service Partners. Repairs performed by unauthorized or unqualified personnel can be dangerous.
- The appliance must be stored in a room without any continuously operating ignition sources (e.g., open flames, gas appliances, or electric heaters).
- Do not pierce or burn the appliance.
- The appliance must be installed, used, and stored in a room with a floor area larger than 4 m<sup>2</sup>.
- This appliance uses flammable refrigerant gas R32. Repairs must be carried out strictly in accordance with the manufacturer's instructions.
- Be aware that some refrigerants may not have a noticeable odor.
- Always refer to the specialist's manual for guidance.

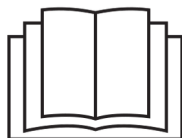

# SAFETY OPERATION OF FLAMMABLE REFRIGERANT

## Qualification requirement for installation and maintenance man

- All personnel involved in servicing the refrigeration system must hold valid certification from a recognized authority, as well as the necessary industry-approved qualifications for working with refrigeration systems.
- If additional technicians are required for maintenance or repair, they must be supervised by a certified individual authorized to handle flammable refrigerants.
- Repairs must be performed only using methods approved by the equipment provider or in accordance with official technical guidelines.

## Installation Notes

- The air conditioner must not be used in rooms with an active flame (e.g., open fire, operating gas appliances, or heaters).
- Drilling or applying heat to the refrigerant piping is strictly prohibited.
- The air conditioner must be installed in a room that meets or exceeds the minimum room size specified on the nameplate or in Table A.
- A leak test is mandatory after installation.

**Table A - Minimum Room Area ( $m^2$ )**

Charge Amount (kg)	Minimum Room Area ( $m^2$ )			
	Floor Location	Window Mounted	Wall Mounted	Ceiling Mounted
≤ 1.2	/	/	/	/
1.3	14.5	5.2	1.6	2.6
1.4	16.8	6.1	1.9	2.8
1.5	19.3	7.0	2.1	3.0
1.6	22.0	7.9	2.4	3.2
1.7	24.8	8.9	2.8	3.4
1.8	27.8	10.0	3.1	3.6
1.9	31.0	11.2	3.4	3.8
2.0	34.3	12.4	3.8	4.0
2.1	37.8	13.6	4.2	4.2
2.2	41.5	15.0	4.6	4.4
2.3	45.4	16.3	5.0	4.6
2.4	49.4	17.8	5.5	4.8
2.5	53.6	19.3	6.0	5.0
2.6	58.1	20.9	6.5	5.2
2.7	62.6	22.6	7.0	5.4
2.8	67.4	24.3	7.5	5.6
2.9	72.3	26.0	8.1	5.8
3.0	77.3	27.9	8.6	6.0
3.1	82.6	29.8	9.2	6.2
3.2	88.0	31.7	9.8	6.6
3.3	93.6	33.7	10.4	7.0
3.4	99.3	35.8	11.1	7.4
3.5	105.2	37.9	11.7	7.9
3.6	111.3	40.1	12.4	8.3
3.7	117.6	42.4	13.1	8.8
3.8	124.0	44.7	13.8	9.3
3.9	130.7	47.1	14.6	9.8
4.0	137.4	49.4	15.3	10.3

## Maintenances Notes

- Check if the maintenance or room area meets the requirements stated on the nameplate. Operation is only permitted in rooms that comply with the nameplate specifications.
- Ensure the maintenance area is well-ventilated. Continuous ventilation must be maintained throughout the operation.
- Check for any fire sources or potential ignition sources in the maintenance area. Open flames are strictly prohibited, and a **"No Smoking"** warning sign must be clearly displayed.
- Inspect the appliance warning labels. Replace any labels that are unclear or damaged.

## Welding

- If cutting or welding of the refrigerant system pipes is required during maintenance, please follow the steps below:
  - a. Shut down the unit and disconnect the power supply.
  - b. Recover or eliminate the refrigerant safely.
  - c. Perform vacuuming.
  - d. Clean the system using Nitrogen (N<sub>2</sub>) gas.
  - e. Proceed with cutting or welding as needed.
  - f. Transport the unit to the service location for welding.
- The refrigerant should be recovered into a designated storage tank.
- Ensure there are no open flames near the vacuum pump outlet, and make sure the area is well-ventilated.

## Filling the refrigerant

- Use refrigerant filling equipment specifically designed for R32. Ensure that different types of refrigerants do not mix.
- Keep the refrigerant tank upright while filling.
- Attach a label to the system after filling—whether completed or not.
- Do not overfill.
- After filling, perform a leak test before running the system. Perform another leak test when the system is removed.

## Safety Instructions for transportation and storage

- Use a flammable gas detector to check for gas leaks before unloading and opening the container.
- Keep the area free of fire sources and do not smoke.
- Follow all applicable local laws and regulations.

# SPECIALIST'S MANUAL

- **The following checks shall be applied to installations using flammable refrigerants:**

- the charge size is in accordance with the room size within which the refrigerant containing parts are installed;
- the ventilation machinery and outlets are operating adequately and are not obstructed;
- if an indirect refrigerating circuit is being used, the secondary circuit shall be checked for the presence of refrigerant;
- marking to the equipment continues to be visible and legible. Markings and signs that are illegible shall be corrected;
- refrigeration pipe or components are installed in a position where they are unlikely to be exposed to any substance which may corrode refrigerant containing components, unless the components are constructed of materials which are inherently resistant to being corroded or are suitably protected against being so corroded.

- **Checking for presence of refrigerant**

The area shall be checked with an appropriate refrigerant detector prior to and during work, to ensure the technician is aware of potentially toxic or flammable atmospheres. Ensure that the leak detection equipment being used is suitable for use with all applicable refrigerants, i.e. non-sparking, adequately sealed or intrinsically safe.

- **Presence of fire extinguisher**

If any hot work is to be conducted on the refrigeration equipment or any associated parts, appropriate fire extinguishing equipment shall be available to hand. Have a dry powder or CO<sub>2</sub> fire extinguisher adjacent to the charging area.

- **No ignition sources**

No person carrying out work in relation to a refrigeration system which involves exposing any pipe work shall use any sources of ignition in such a manner that it may lead to the risk of fire or explosion. All possible ignition sources, including cigarette smoking, should be kept sufficiently far away from the site of installation, repairing, removing and disposal, during which refrigerant can possibly be released to the surrounding space. Prior to work taking place, the area around the equipment is to be surveyed to make sure that there are no flammable hazards or ignition risks. "No Smoking" signs shall be displayed.

- **Ventilated Area**

Ensure that the area is in the open or that it is adequately ventilated before breaking into the system or conducting any hot work. A degree of ventilation shall continue during the period that the work is carried out. The ventilation should safely disperse any released refrigerant and preferably expel it externally into the atmosphere.

- **Checks to the refrigeration equipment**

Where electrical components are being changed, they shall be fit for the purpose and to the correct specification. At all times the maintenance and service guidelines shall be followed. If in doubt, consult Kolin Service Hotline or its Authorized Service Partners for assistance.

The following checks shall be applied to installations using flammable refrigerants:

- the actual refrigerant charge is in accordance with the room size within which the refrigerant containing parts are installed;
- the ventilation machinery and outlets are operating adequately and are not obstructed;
- if an indirect refrigerating circuit is being used, the secondary circuit shall be checked for the presence of refrigerant;
- marking to the equipment continues to be visible and legible. Markings and signs that are illegible shall be corrected;
- refrigerating pipe or components are installed in a position where they are unlikely to be exposed to any substance which may corrode refrigerant containing components, unless the components are constructed of materials which are inherently resistant to being corroded or are suitably protected against being so corroded.

- **Checks to electrical devices**

Repair and maintenance to electrical components shall include initial safety checks and component inspection procedures. If a fault exists that could compromise safety, then no electrical supply shall be connected to the circuit until it is satisfactorily dealt with. If the fault cannot be corrected immediately but it is necessary to continue operation, an adequate temporary solution shall be used. This shall be reported to the owner of the equipment so all parties are advised.

Initial safety checks shall include:

- that capacitors are discharged: this shall be done in a safe manner to avoid possibility of sparking;
- that no live electrical components and wiring are exposed while charging, recovering or purging the system;
- that there is continuity of earth bonding.

#### • **Repairs to sealed components**

During repairs to sealed components, all electrical supplies shall be disconnected from the equipment being worked upon prior to any removal of sealed covers, etc. If it is absolutely necessary to have an electrical supply to equipment during servicing, then a permanently operating form of leak detection shall be located at the most critical point to warn of a potentially hazardous situation.

Particular attention shall be paid to the following to ensure that by working on electrical components, the casing is not altered in such a way that the level of protection is affected. This shall include damage to cables, excessive number of connections, terminals not made to original specification, damage to seals, incorrect fitting of glands, etc.

- Ensure that the apparatus is mounted securely.
- Ensure that seals or sealing materials have not degraded to the point that they no longer serve the purpose of preventing the ingress of flammable atmospheres. Replacement parts shall be in accordance with the manufacturer's specifications.

**NOTE:** The use of silicon sealant can inhibit the effectiveness of some types of leak detection equipment. Intrinsically safe components do not have to be isolated prior to working on them.

#### • **Repair to intrinsically safe components.**

Do not apply any permanent inductive or capacitance loads to the circuit without ensuring that this will not exceed the permissible voltage and current permitted for the equipment in use. Intrinsically safe components are the only types that can be worked on while live in the presence of a flammable atmosphere. The test apparatus shall be at the correct rating.

Replace components only with parts specified by the manufacturer. Other parts may result in the ignition of refrigerant in the atmosphere from a leak.

#### • **Cabling**

Check that cabling will not be subject to wear, corrosion, excessive pressure, vibration, sharp edges or any other adverse environmental effects. The check shall also take into account the effects of aging or continual vibration from sources such as compressors or fans.

#### • **Detection of flammable refrigerants**

Under no circumstances shall potential sources of ignition be used in the searching for or detection of refrigerant leaks. A halide torch (or any other detector using a naked flame) shall not be used.

The following leak detection methods are deemed acceptable for all refrigerant systems. Electronic leak detectors may be used to detect refrigerant leaks but, in the case of flammable refrigerants, the sensitivity may not be adequate, or may need re-calibration. (Detection equipment shall be calibrated in a refrigerant-free area.) Ensure that the detector is not a potential source of ignition and is suitable for the refrigerant used. Leak detection equipment shall be set at a percentage of the LFL of the refrigerant and shall be calibrated to the refrigerant employed, and the appropriate percentage of gas (25 % maximum) is confirmed. Leak detection fluids are also suitable for use with most refrigerants but the use of detergents containing chlorine shall be avoided as the chlorine may react with the refrigerant and corrode the copper pipe-work.

#### **NOTE:**

Examples of leak detection fluids are

- bubble method,
- fluorescent method agents.

If a leak is suspected, all naked flames shall be removed/extinguished.

If a leakage of refrigerant is found which requires brazing, all of the refrigerant shall be recovered from the system, or isolated (by means of shut off valves) in a part of the system remote from the leak. Removal of refrigerant shall be according to Clause **Removal and Evacuation.**

## • Removal and Evacuation

When you're working on a refrigerant circuit, especially with flammable refrigerants, safety is paramount. Standard procedures apply, but with flammable gases, you've got to follow best practices to prevent hazards. Here's the critical procedure you must adhere to:

- Remove Refrigerant: Start by completely recovering the refrigerant charge into the correct recovery cylinders.
- Purge with Inert Gas: Next, purge the circuit thoroughly with an inert gas.
- Evacuate: Pull the system down to a vacuum.
- Purge Again: Repeat the purge with inert gas.
- Open the Circuit: Only then can you safely open the circuit by cutting or brazing.

For systems containing flammable refrigerants, you must "flush" the unit with Oxygen-Free Nitrogen (OFN) to make it safe. This process might need to be repeated several times. Never use compressed air or oxygen for purging refrigerant systems. Here's how to properly flush appliances with flammable refrigerants:

1. Break the Vacuum: Introduce OFN into the system to break the vacuum.
2. Fill to Working Pressure: Continue filling the system with OFN until it reaches working pressure.
3. Vent to Atmosphere: Carefully vent the OFN to the atmosphere.
4. Pull Down to Vacuum: Finally, pull the system down to a vacuum again.

Repeat this entire process until you're absolutely certain there's no refrigerant left in the system. When you're ready for the final OFN charge, vent the system down to atmospheric pressure. This step is absolutely vital if you plan to perform brazing operations on the pipework.

Always ensure that the outlet for your vacuum pump isn't near any ignition sources and that you have adequate ventilation in the work area. Your safety, and the safety of others, depends on strictly following these guidelines.

## • Repairs to sealed

In addition to conventional charging procedures, the following requirements shall be followed.

- Ensure that contamination of different refrigerants does not occur when using charging equipment. Hoses or lines shall be as short as possible to minimize the amount of refrigerant contained in them.
- Cylinders shall be kept upright.
- Ensure that the refrigeration system is earthed prior to charging the system with refrigerant.
- Label the system when charging is complete (if not already).
- Extreme care shall be taken not to overfill the refrigeration system.

Prior to recharging the system, it shall be pressure-tested with the appropriate purging gas. The system shall be leak-tested on completion of charging but prior to commissioning. A follow up leak test shall be carried out prior to leaving the site.

## • Decommissioning

Before carrying out this procedure, it is essential that the technician is completely familiar with the equipment and all its detail. It is recommended good practice that all refrigerants are recovered safely.

Prior to the task being carried out, an oil and refrigerant sample shall be taken in case analysis is required prior to re-use of reclaimed refrigerant. It is essential that electrical power is available before the task is commenced.

- (a) Become familiar with the equipment and its operation.
- (b) Isolate system electrically.
- (c) Before attempting the procedure, ensure that:
  - mechanical handling equipment is available, if required, for handling refrigerant cylinders;
  - all personal protective equipment is available and being used correctly;
  - the recovery process is supervised at all times by a competent person;
  - recovery equipment and cylinders conform to the appropriate standards.
- (d) Pump down refrigerant system, if possible.
- (e) If a vacuum is not possible, make a manifold so that refrigerant can be removed from various parts of the system.

- (f) Make sure that cylinder is situated on the scales before recovery takes place.
- (g) Start the recovery machine and operate in accordance with manufacturer's instructions.
- (h) Do not overfill cylinders. (No more than 80% volume liquid charge).
- (i) Do not exceed the maximum working pressure of the cylinder, even temporarily.
- (j) When the cylinders have been filled correctly and the process completed, make sure that the cylinders and the equipment are removed from site promptly and all isolation valves on the equipment are closed off.
- (k) Recovered refrigerant shall not be charged into another refrigeration system unless it has been cleaned and checked.

- **Labelling**

Equipment shall be labeled stating that it has been de-commissioned and emptied of refrigerant. The label shall be dated and signed. For appliances containing flammable refrigerants, ensure that there are labels on the equipment stating the equipment contains flammable refrigerant.

- **Safety instructions for transportation and storage**

- Before you unload or open the container, please use the flammable gas detector to check for any gas.
- Ensure there are no fire sources or smoking.
- Always comply with local rules and laws.

- **Recovery**

When removing refrigerant from a system, either for servicing or decommissioning, it is recommended good practice that all refrigerants are removed safely. When transferring refrigerant into cylinders, ensure that only appropriate refrigerant recovery cylinders are employed. Ensure that the correct number of cylinders for holding the total system charge are available. All cylinders to be used are designated for the recovered refrigerant and labelled for that refrigerant (i.e. special cylinders for the recovery of refrigerant). Cylinders shall be complete with pressure-relief valve and associated shut-off valves in good working order. Empty recovery cylinders are evacuated and, if possible, cooled before recovery occurs. The recovery equipment shall be in good working order with a set of instructions concerning the equipment that is at hand and shall be suitable for the recovery of all appropriate refrigerants including, when applicable, flammable refrigerants. In addition, a set of calibrated weighing scales shall be available and in good working order. Hoses shall be complete with leak-free disconnect couplings and in good condition. Before using the recovery machine, check that it is in satisfactory working order, has been properly maintained and that any associated electrical components are sealed to prevent ignition in the event of a refrigerant release. Consult manufacturer if in doubt. The recovered refrigerant shall be returned to the refrigerant supplier in the correct recovery cylinder, and the relevant waste transfer note arranged. Do not mix refrigerants in recovery units and especially not in cylinders. If compressors or compressor oils are to be removed, ensure that they have been evacuated to an acceptable level to make certain that flammable refrigerant does not remain within the lubricant. The evacuation process shall be carried out prior to returning the compressor to the suppliers. Only electric heating to the compressor body shall be employed to accelerate this process. When oil is drained from a system, it shall be carried out safely.

# INTRODUCTION AND PARTS IDENTIFICATIONS

## Introduction

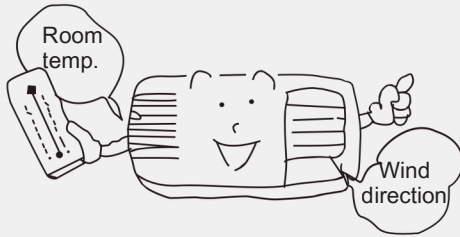

*Window type room air conditioners can regulate the room temperature and dry the room. It is convenient for your work, study and life. It can be widely used in residence, shop, hotel, office, library and laboratory, and so on.*

### Cooling in Summer

*In hot summer, air conditioner can cool down the room air by transferring heat out.*

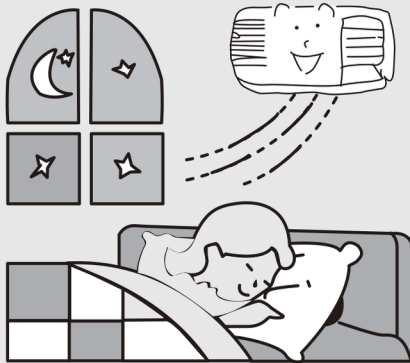

### Dehumidifying in Rainy or Humid Season

*Without reducing the room temperature, air conditioner can dehumidify and make the room air dry and comfortable.*



## Special Functions and Instructions

Sensor	Function
Temperature sensor	It's used for detecting ambient temperature and pipeline temperature.
Infrared receiver	Receive the infrared signal sent from the remote controller.

## Working Temperature Range

WORKING TEMPERATURE RANGE		
	Dry Bulb Temp	Wet Bulb Temp
Indoor Side Condition	32°C (90°F)	23°C (73°F)
Outdoor Side Condition	43°C (109°F)	-

*\*Dry Bulb Temperature (DBT) refers to the regular air temperature measured with a standard thermometer.*

*\*\*Wet Bulb Temperature (WBT) reflects humidity and is measured with a thermometer wrapped in a wet cloth.*

## Parts Identification

Panel outlook picture is for reference only; please consider the actual unit as the standard.

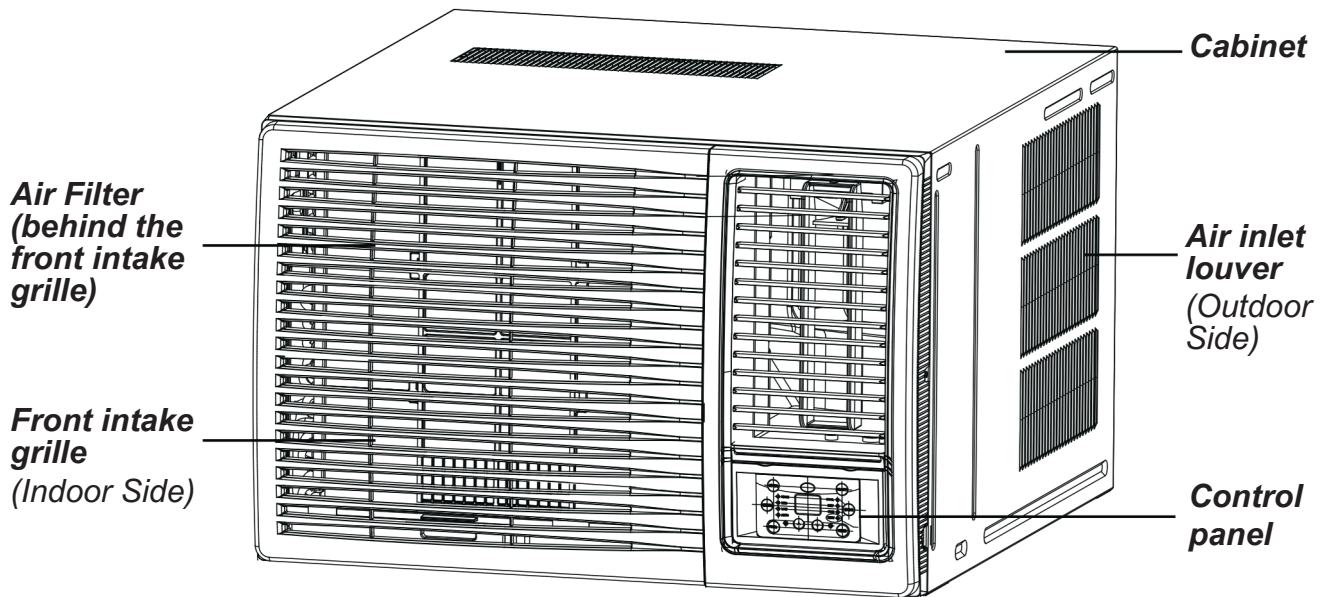

This unit model features a built-in temperature sensor for collecting ambient and inner tube temperature, as well as a built-in infrared signal receiver for receiving infrared remote signals.

### Air Direction Adjustment

- **Vertical Airflow Direction Vane**

(Airflow direction adjustment up and down)

The vertical airflow direction vane is controlled by positioning the vane to discharge the air upwards, downwards or straight out.

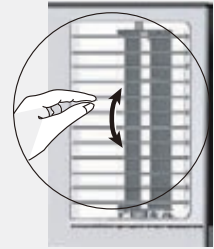

## Electrical Requirement

### Rated voltage :230V~ 60Hz

The electric components will be damaged when the voltage is too high. If the voltage is too low, the compressor will vibrate violently that will damage the refrigerant system and easily cause the compressor and electric components not to work.

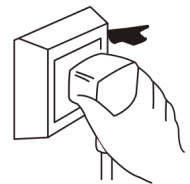

### The ground must be connected.

- Special socket must be used. Furthermore, the socket and wiring must conform to the wiring regulations. And the earthing method must be reliable.
- In a fixed electrical circuit, it is essential to install a leakage protection switch with an adequate power capacity and a circuit breaker that is correctly sized for the circuit.



**USE A PROPERLY GROUNDED 3-PRONG OUTLET. NEVER REMOVE OR CUT THE GROUND PIN. DO NOT USE ADAPTERS OR EXTENSION CORDS.**

### Earth Wire

To ensure the reliable earthing, please do not connect earth wire to the following places:



# INSTALLATION

## Installation Precaution:

- Window-type air conditioners are premium appliances, and improper installation can lead to major damage. For proper installation, please contact Kolin Service Hotlines or an Authorized Service Partner near you. Do not attempt to install the unit yourself, as any resulting damage will not be covered by our warranty or responsibility.

## NOTES FOR INSTALLATION

### Relocate

- Before relocating the air conditioner, you should contact the seller first. Then it must be done under the direction of an Authorized Kolin Technician. Contact Kolin Service Hotline or its Authorized Service Partners for assistance. In addition, charges for this must be paid.

### Noise

- Install in a location where it is strong enough to avoid increased noise and vibration.
- Don't put anything in front of the outlet of the unit to avoid increasing noise.
- Be sure that the hot air or noise will not cause inconvenience to neighbors.
- Please contact the seller as soon as there is strange noise during operation.
- Please use the safety support.

### Electric wiring

- Must be connected with ground reliably.
- Use the correct power outlet for the air conditioner. Do not use a plug adaptor because it can overheat and cause fire.
- Don't pull the power cord forcibly.
- In a fixed circuit, there must be an electricity leakage protection switch and the leakage current should be less than 30mA.
- The connecting method between the air conditioner and the power cord, and the interconnecting method of each individual element with one another, should accord with the wiring diagram on the unit.
- The air conditioner should be installed in accordance with national wiring regulations.
- An all-pole disconnection switch having a contact separation of at least 3mm in all poles should be connected in fixed wiring.
- A Circuit (thermal-magnetic breaker) should be installed in the circuit.
- If the supply cord is damaged, contact Kolin Service Hotline or its Authorized Service Partners for replacement to avoid a hazard.
- All electrical work must be done according to the local wiring regulations.

## How to Install:

1. Choose a location where there are no obstacles surrounding the unit and the plug is accessible.

### Location:

When choosing a location for your air conditioner, ensure the following:

- Condensation water can be drained conveniently.
- The unit is installed far away from TVs, radios, and similar electronics to avoid interference.
- **(For specific environments)** If in a salt/coastal area, near thermal springs, or in areas with sulfurous gas pollution, contact your dealer, Kolin Service Hotline or its Authorized Service Partners for assistance before use.
- Avoid areas where flammable gases may leak.
- Do not install near other heat sources or under direct sunlight.
- Choose a location that is out of reach of children.
- Do not install the unit near laundry areas, bathrooms, showers, or swimming pools.
- If the installation site is subject to strong electromagnetic interference, contact your dealer, the Kolin Service Hotline or its Authorized Service Partners beforehand to avoid potential malfunctions.

2. Prepare the installation hole to be slightly larger than the unit size.
3. Choose the installation space according to the following diagram.
4. If there is an obstacle near the air conditioner, ensure that only one surrounding obstacle is present. Having multiple obstacles around the unit will reduce its operating efficiency. However, if no obstacle is necessary, then maintaining these clearances is not required. In cases where an obstacle is present, the distance between the air conditioner and the obstacle should meet the following requirements:

- Lower side: At least 1800 mm

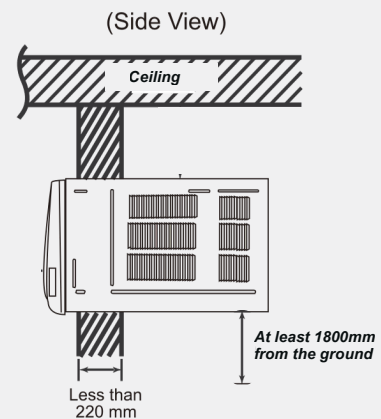

- Front side: Over 1500mm

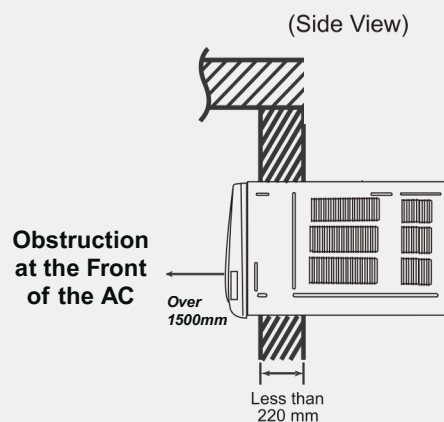

- Rear Side: Over 1000mm

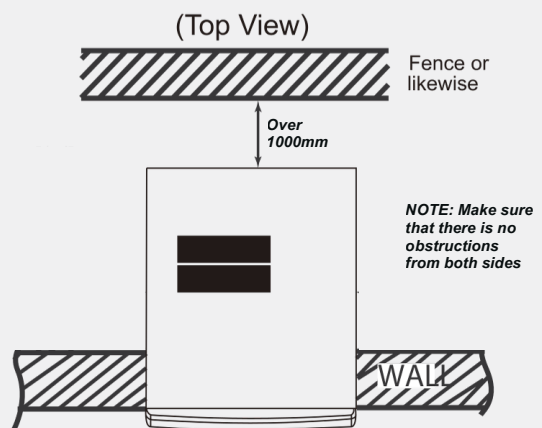

- Left side: Over 500 mm
- Right side: Over 500 mm

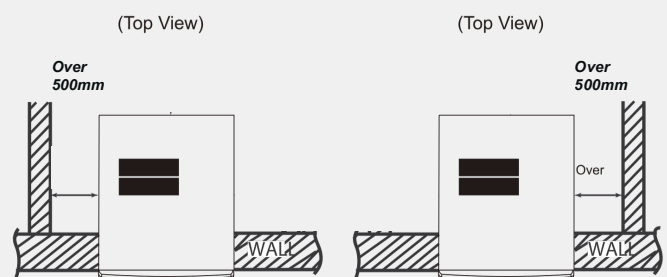

## Installation Procedure

1. Remove the sticker from the front panel.
2. Place the unit into the installation hole.
  - When installing the unit, it should **slant downwards toward the back** to ensure condensation water drains properly. (Approximately a  $3^{\circ}\pm 1^{\circ}$  slant, as shown in the figure 1.)
  - The installation place must be strong enough to prevent more noise or vibration.
3. Fill the gaps in the cabinet with sponge or foam.

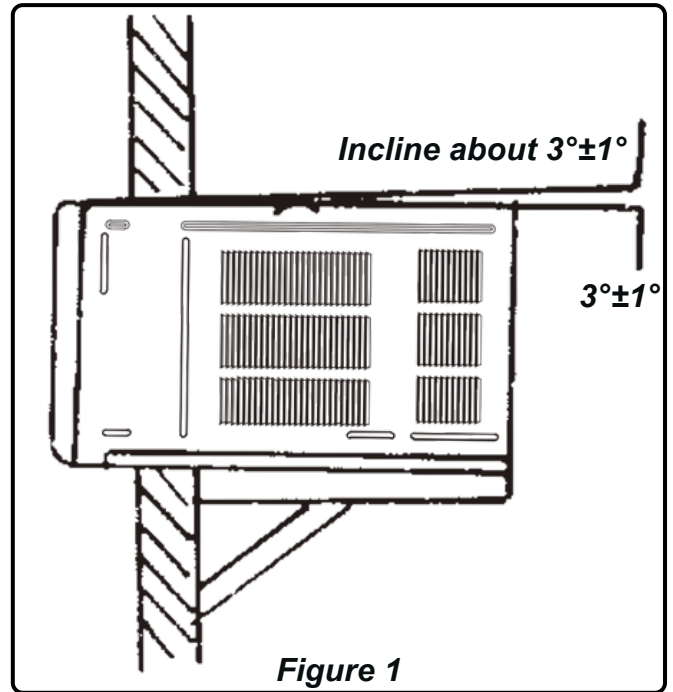

## Installation Support

### Use Iron Support

- The installation hole must be strong enough to support the air conditioner. If it is not, an iron support must be used outdoors. This iron support should be securely fixed to the building, as shown in the figure 2.

### Use a Sunshade Board

- The air conditioner should be protected from falling objects and direct sunlight. If there is no existing cover, contact the seller to install a sunshade board. When installing the sunshade board, contact Kolin Service Hotline or its Authorized Service Partners for installation to ensure it does not block the air inlet at the side grille.

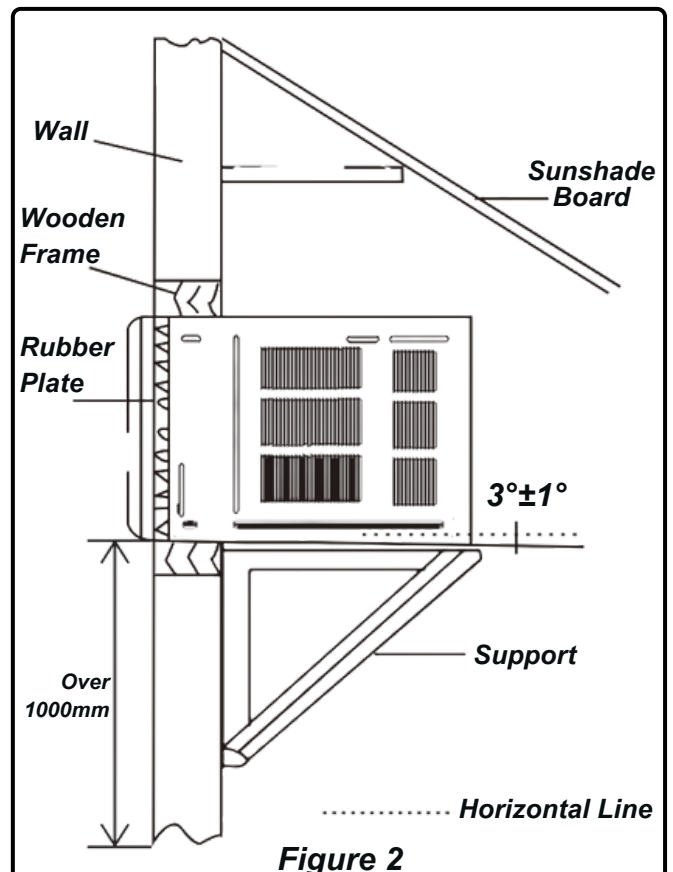

## Drain Pan and Drain Hose

Drain pan and drain hose need to be installed before use.

*Note: The drain hose is not included with the product. You need to purchase it locally according to your specific needs.*

Follow these steps to install the drain pan and drain hose:

1. Slide out the chassis from the cabinet.
2. Install the drain pan to the corner of the cabinet with two screws.
3. Connect the drain hose to the outlet at the bottom of the drain pan.
4. Slide the chassis back into its original position inside the cabinet.

### Drain Hose Size:

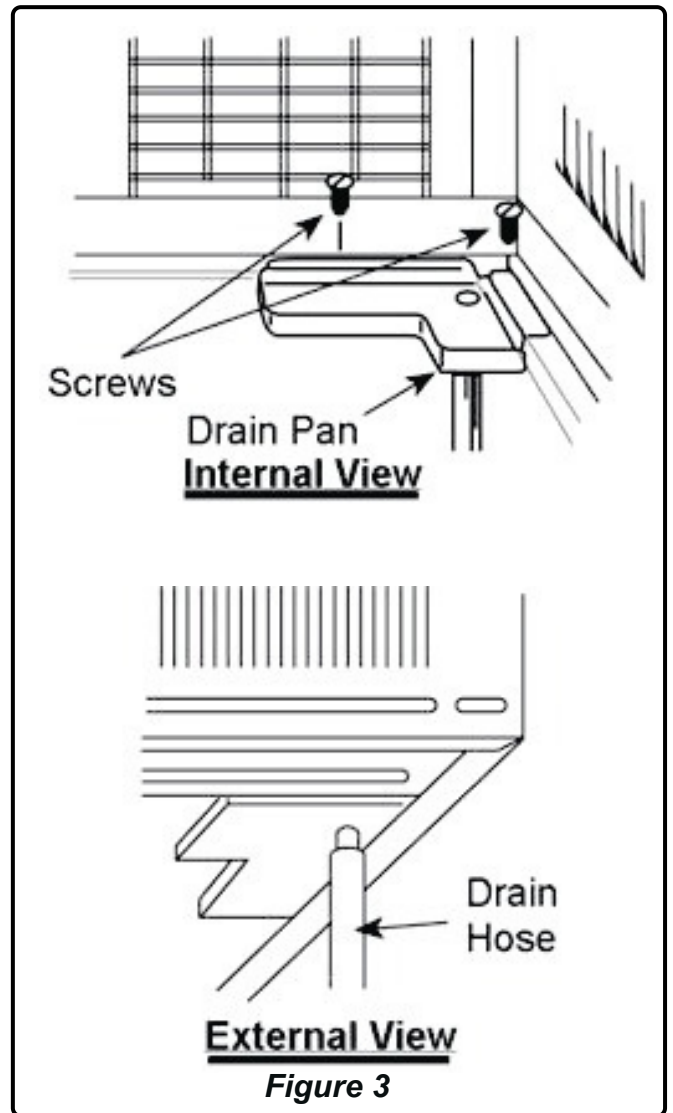
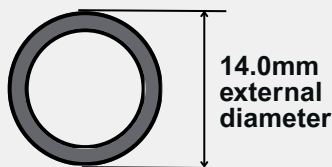
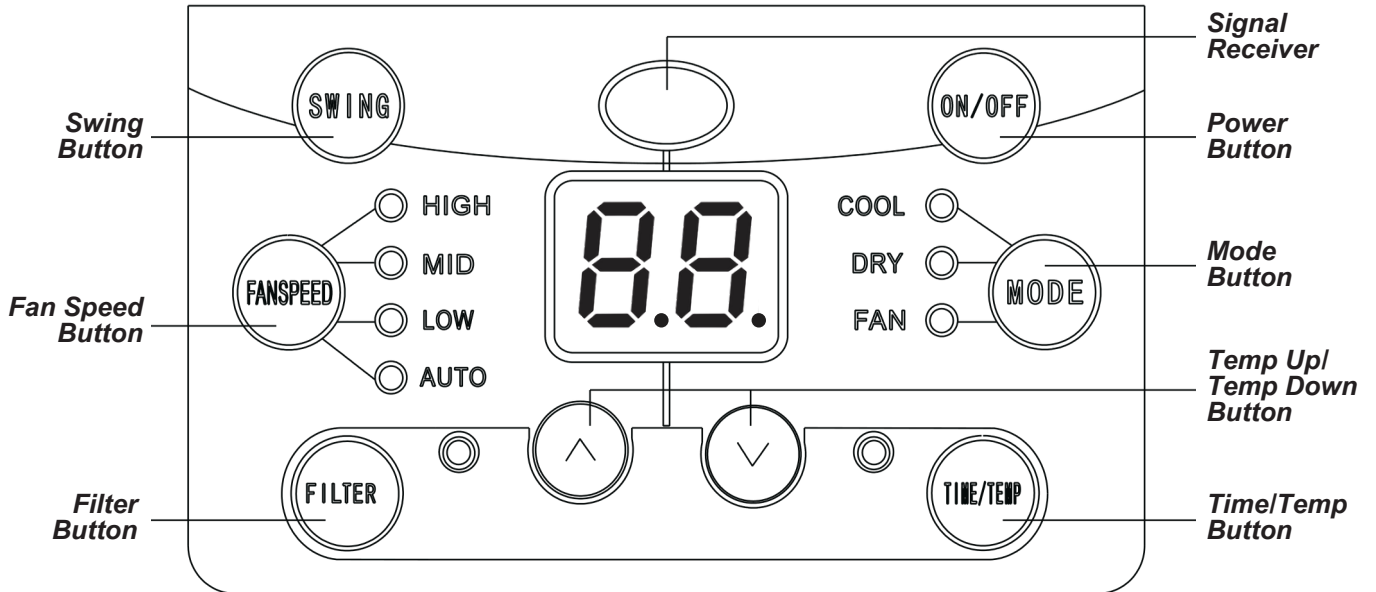

**Figure 3**

**NOTE:** To achieve maximum cooling efficiency, the air conditioner is designed to splash condensation water onto the condenser coil. If the splashing sound is troublesome, you may remove the rubber plug from the chassis to reduce the noise. However, this may slightly reduce the unit's performance.

# CONTROL PANEL

If the wireless remote controller is lost, you can manually operate the unit using the control panel; the figure shown in the instruction manual is for reference only—please refer to the actual product for accurate layout.



## SIGNAL RECEIVER

- A signal receiver detects commands from the remote control when it's pointed toward it and within range, then directs the aircon to perform the selected function.



## POWER BUTTON

- Press this button to turn the unit on or off. When turned off, the unit enters standby mode, unless it is disconnected from the power source.

## MODE BUTTON

- Pressing this button cycles through the modes shown below. The mode indicator will light up to display which mode is active.



### COOL MODE

- Cools the room to your desired temperature.
- *You can change the temperature and fan speed on this mode.*

### DRY MODE

- Reduces humidity in the room without major change in temperature.
- *Fan speed cannot be adjusted on this mode (Default: Low fan speed). Temperature can be adjusted.*

### FAN MODE

- Circulates air without cooling or heating.
- *Temperature cannot be adjusted on this mode. Fan speed can be adjusted.*



## TIME/TEMP BUTTON

### Setting Temperature

- The default display of the LED display is the set temperature. Press the temp up and temp down buttons to choose desired temperature.



Increase set temperature



Decrease set temperature

### Setting Timer

- When unit and remote is ON  
→ The set time is for Timer OFF
- When unit and remote is OFF  
→ The set time is for Timer ON
- When you save the set time, the unit will begin a countdown, and once it reaches zero, the unit will turn on/off.

- Pressing this button to set the timer button. The LED display on the unit will blink. Press the **temp up** and **temp down** to navigate the desired time of operation.

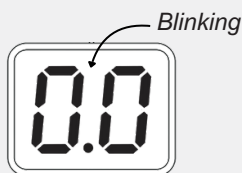

Set Time Forward



Set Time Backward

### TIME OPTION CYCLE

0.0 – 0.5 – 1.0 – 1.5 – 2.0 – 2.5 – 3.0 – 3.5 –  
4.0 – 4.5 – 5.0 – 5.5 – 6.0 – 6.5 – 7.0 – 7.5 –  
8.0 – 9.5 – 10 – 11 – 12 – 13 – 14 – 15 – 16 –  
17 – 18 – 19 – 20 – 21 – 22 – 23 – 24

- Wait for 5 seconds to save the set time.

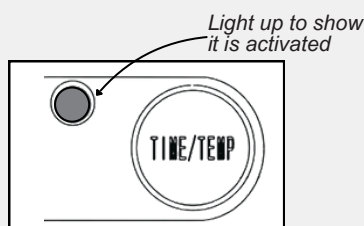

## SWING BUTTON

- Pressing this button will activate the automatic left and right swing of the vertical louver. The up and down swing can only be adjusted manually.



## FAN SPEED BUTTON

- Press this button to select desired fan speed. The fan speed will cycle as shown below.



## FILTER BUTTON

### Filter Dirty Alarm

- This feature reminds you to clean the Air Filter (see Care and Maintenance for details) for efficient operation and cooling.
- The LED will illuminate after 250 hours of operation. To reset it after cleaning the filter, press the "Filter" button until the light turns off.
- To cancel the accumulated operating time before the LED illuminates, press the "Filter" button for 3 seconds.

Light up to show that the 250 hours is up and its time to clean your filters.

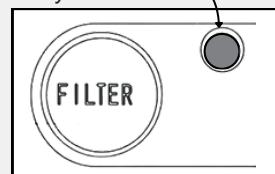

# REMOTE OPERATIONS

## NOTES:

- Ensure there are no obstructions between the remote controller and the signal receiver.
- Do not drop or throw the remote controller.
- Keep the remote controller away from liquids, direct sunlight, and high-temperature areas.
- This is a general-purpose remote controller. Pressing a button not supported by the unit will not change its current operating status.

## Buttons and Functions

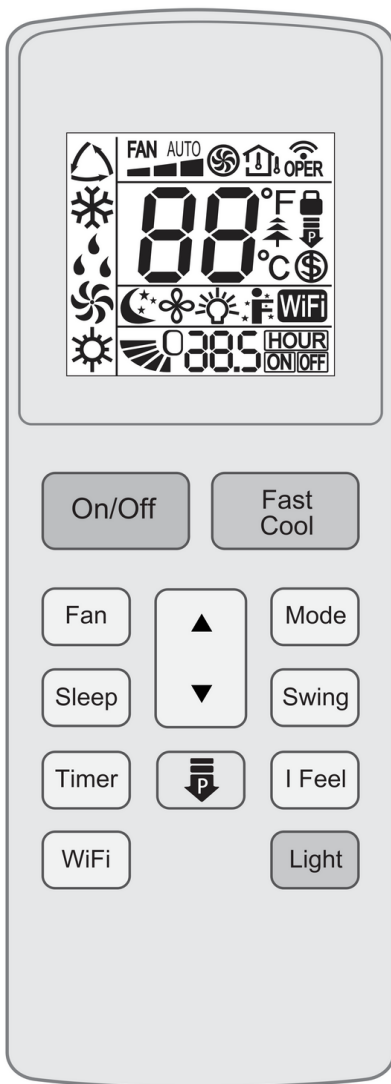

BUTTON	DESCRIPTIONS
On/Off	<b>POWER BUTTON:</b> Turn the unit ON or OFF. <i>(Default Mode: Cool Mode)</i>
Fast Cool	<b>FAST COOL:</b> Enables quick cooling at 25°C or 16°C with high fan speed.
Fan	<b>FAN:</b> Sets the fan speed from Auto, three speed levels, and turbo mode.
Sleep	<b>SLEEP:</b> Enables or disables Sleep mode. <i>Applicable on Cool Mode only</i>
Timer	<b>TIMER:</b> Sets a time to automatically turn the unit on or off.
WiFi	<b>WIFI:</b> Turns WiFi connectivity on or off.
▲	<b>TEMP UP:</b> Increases temperature by 1(°C or °F) <i>Note: Maximum temperature is 30°C / 86°F.</i>
▼	<b>TEMP DOWN:</b> Decreases temperature by 1(°C or °F). <i>Note: Minimum temperature is 16°C / 61°F.</i>
⏻	<b>POWER REDUCTION:</b> Limits the maximum power consumption of the air conditioner.
Mode	<b>MODE:</b> Cycles between Cool, Dry, and Fan modes.
Swing	<b>SWING:</b> Activates or deactivates automatic air swing.
I Feel	<b>I-FEEL:</b> Senses the surrounding temperature at the remote and adjusts cooling accordingly.
Light	<b>LIGHT:</b> Turns the display light on or off.

*Not all the buttons on the remote control will function on some models.*

# Remote Screen Display Indicators

Information is displayed in the remote control.



Note: All indicators shown above are for information purposes only. During actual operation, only the relevant indicators will be shown on the display.

**MODE Display:** Displays the current mode



**FAN SPEED**

Auto → FAN AUTO

Low → FAN

Med → FAN

High → FAN

Turbo\* → FAN



Temp Display Type



Set Temp.\*



Indoor Ambient Temp.



Outdoor Ambient Temp.\*



Remote Signal Indicator



Displays the set temperature (default), indoor temperature or outdoor temperature.



UNIT (Fahrenheit)



Health Function\*



UNIT (Celsius)



Child Lock Function



Power Limiting Operation



8°C heating function\*



Sleep Function



X-Fan Function



Light Function



I-Feel Function



WiFi Function



Horizontal Louver Swing



Displays time for setting Timer ON/Timer OFF settings



Timer ON Timer OFF

\*NA - Not applicable for this model

\*\*Other functions and features are only applicable for some models

## HOW TO USE BASIC FUNCTIONS

### NOTES:

- Make sure there are no obstacles between the remote controller and the receiver on the unit.
- Do not drop or throw the remote controller.
- Keep the remote away from liquids, direct sunlight, and high temperatures.
- This is a general-use remote controller designed for multifunction air conditioners. If you press a button that your model doesn't support, the unit will continue operating normally without any changes.
- When power is connected, the air conditioner will emit a sound and the power indicator will light up. You can then use the remote controller to operate the unit.
- When the unit is ON, pressing a button on the remote will make the signal icon blink once, and the unit will emit a “di” sound to confirm the signal was received.

Fast Cool

### FAST COOL BUTTON

- When in Cool mode, repeatedly pressing this button cycles through:

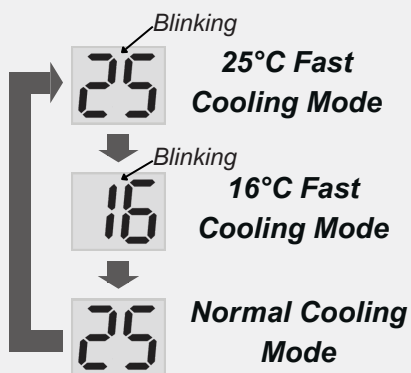

### Fast Cooling Mode

- When entering a fast cooling mode, the **fan speed automatically sets to AUTO**, and the target temperature becomes **25°C or 16°C**.
- The set temperature will blink on the display for 5 seconds. During this blinking period, you can press the TEMP UP or TEMP DOWN buttons to adjust the set temperature, or the FAN button to adjust the fan speed.

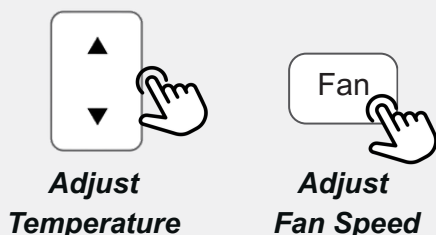

- If no adjustments are made within the 5-second blinking period, the remote and indoor unit will operate at the current set temperature and fan speed for 20 minutes. After 20 minutes, both the remote and the unit will revert to the settings they had before entering fast cooling mode.

### NOTE

- If you adjust the set temperature or fan speed while in fast cooling mode, the unit will exit fast cooling mode and continue operating under the newly adjusted settings.
- *This function is only applicable to certain models. If your indoor unit does not support this function, after 20 minutes, the remote controller will revert to its state before the last cooling mode, and the indoor unit will continue its current operation, potentially causing a display discrepancy between the unit and the remote.*

Fan

## FAN BUTTON

- Press this button to adjust the fan speed. The fan speed will cycle through this:



### NOTE:

- Fan speed can not be adjusted on dry mode. Default fan speed is low fan speed.
- **The Turbo fan speed feature is not supported on some models. For certain models, the Turbo fan speed is equivalent to the High fan speed.**

### X-FAN FUNCTION

- X-FAN helps remove moisture from the indoor unit after shutdown by keeping the fan running briefly.
- In Cool or Dry mode, press and hold the Fan button for 2 seconds to activate X-FAN. The X-FAN icon will appear on the display. The indoor fan will continue running for a few minutes after the unit is turned off to **help dry the evaporator** and **prevent mold growth**. By default, X-FAN is off when the unit is powered on. *This function is not available in Auto, Fan, or Heat modes.*

#### When X-FAN is ON:

- After turning off the unit using the ON/OFF button, the indoor fan will continue operating at low speed for a few minutes. To stop the fan immediately during this time, press and hold fan speed button for 2 seconds.

#### When X-FAN is OFF:

- After turning off the unit using the ON/OFF button, the entire unit will shut down immediately.



The X-Fan function indicator will appear on the screen to confirm it is activated.

**\*The X-Fan function is only available for some models.**

Mode

## MODE BUTTON

- Pressing this button cycles through the modes shown below. The mode indicator will light up to display which mode is active.

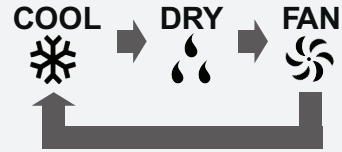

### COOL MODE

- Cools the room to your desired temperature.
- You can change the temperature and fan speed on this mode.

### DRY MODE

- Reduces humidity in the room without major change in temperature.
- Fan speed cannot be adjusted on this mode (Default: Low fan speed). *Temperature can be adjusted.*

### FAN MODE

- Circulates air without cooling or heating.
- Temperature cannot be adjusted on this mode. Fan speed can be adjusted.

Sleep

## SLEEP BUTTON

- Press this button to activate Sleep Mode. During Cool mode, after one hour, the set temperature will increase by 1°C. After two hours, it will increase by 2°C in total. The unit will then maintain this temperature for the rest of the operation.
- *The default fan speed in Sleep Mode is low.*
- *You can adjust the fan speed while in Sleep Mode. However, selecting "turbo" fan speed or "auto" fan speed will automatically cancel Sleep Mode.*
- *Sleep Mode is only functional when the air conditioner is operating in Cool Mode.*



The Sleep function indicator will appear on the screen to confirm it is activated.

Swing

**SWING BUTTON**

- Press this button to adjust the horizontal swing. The cycle will be as follows:

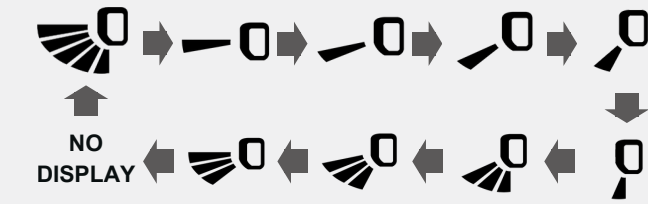

	Automatically swing left and right.
	Stops at current louver position.
	Automatically swing left and right.
NO DISPLAY	Stops at current louver position.

*\*Some angles may not be available on this model.  
This function is only available for some models.*

I Feel

**I FEEL BUTTON**

- Press this button to activate the I FEEL function. The I FEEL icon will appear on the remote display, and the remote will begin sending the detected ambient temperature to the indoor unit. The air conditioner will then automatically adjust the indoor temperature based on this reading.
- Press the button again to cancel the I FEEL function. The icon will disappear.
- For accurate temperature detection, keep the remote near the user and away from hot or cold objects. Make sure the remote stays within the range of the indoor unit to ensure proper signal transmission.

*\*Works only in Cool and Dry modes.*

 The I-Feel function indicator will appear on the screen to confirm it is activated.

*This function is only available for some models.*

Timer

**TIMER BUTTON****TIMER ON**

- To set timer ON, the **unit must be on standby mode** and **the remote is turned OFF**.
- Press the TIMER button once, the HOUR and ON icons on remote display will be blinking. While blinking press the TEMP UP and TEMP DOWN button to choose the desired time to turn ON the unit.
- Time range from 0.5 hr to 24 hr with 0.5 hr increment.**



Set Time  
Forward



Set Time  
Backward



- Once you have selected the desired time, press the TIMER button again to save the TIMER ON settings. The time and corresponding icons will be displayed on the remote and will begin counting down. When the set time is reached, the unit will turn on and the timer icons will disappear from the display.
- If the icons are blinking and you do not press the TIMER button, the setting will be automatically canceled. Additionally, if you have saved a setting and then press the TIMER button again, that setting will also be canceled.*

## TIMER OFF

- To set timer OFF, the **unit must be powered ON** and **the remote is turned ON**.
- Press the TIMER button once, the HOUR and OFF icons on remote display will be blinking. While blinking press the TEMP UP and TEMP DOWN button to choose the desired time to turn OFF the unit.
- Time range from 0.5 hr to 24 hr with 0.5 hr increment.**

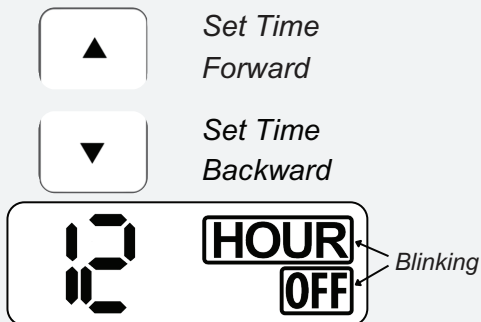

- Once you have selected the desired time, press the TIMER button again to save the TIMER OFF settings. The time and corresponding icons will be displayed on the remote and will begin counting down. When the set time is reached, the unit will turn off and the timer icons will disappear from the display.
- If the icons are blinking and you do not press the TIMER button, the setting will be automatically canceled. Additionally, if you have saved a setting and then press the TIMER button again, that setting will also be canceled.



## LOCK FUNCTION

Press and hold **TEMP UP and TEMP DOWN buttons** together simultaneously for 3 seconds to lock the remote keyboard. Press together simultaneously again for 3 seconds to unlock.



## POWER REDUCTION MODE BUTTON

- This button is used to activate a function that limits the maximum power consumption of the entire air conditioning unit.

How to Activate:

- Press this button to cycle through different power limiting modes.

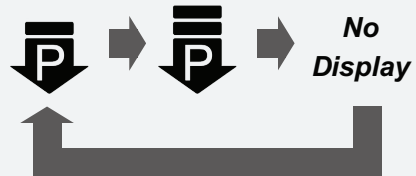

**Power Reduction 1:** Medium power limit, balancing energy saving with comfort.



**Power Reduction 2:** Lowest power limit for maximum energy savings.

**No Display Normal Operation:** No power limit; unit runs at full capacity for maximum cooling.

The following codes will be shown on the unit's LED Display to show it is active



**Power Reduction 1**



**Power Reduction 2**

## NOTES

- If you want to cancel the power limiting function, press the button until the "No Setting" icon is displayed.
- If the remote controller is turned off, the power limiting function will be canceled. To reactivate it, you must press the button again after turning the remote back on.
- If the current power consumption is already lower than the maximum power limit you select, the unit's power will not be further limited.
- This function is only available for specific models.*

WiFi

## WIFI BUTTON

- This button controls your air conditioner's WIFI connection.

### To turn **WIFI ON**

- Press the WIFI button. The WIFI icon will appear on the remote.

### To turn **WIFI OFF**

- Press the WIFI button again. The WIFI icon will disappear.

### To reset **WIFI**

- When the unit is OFF, press and hold both the MODE and WIFI buttons at the same time for 1 second. This resets the WIFI settings.



The WiFi function indicator will appear on the screen to confirm it is activated.

Light

## LIGHT BUTTON

- Press this button to turn the indoor unit's display light ON or OFF. By default, the light is ON after the unit is powered on.



The light function indicator will appear on the screen to confirm it is activated.

## TEMPERATURE DISPLAY SWITCHOVER FUNCTION

- Ensure the **remote is off**, press the MODE and TEMP DOWN buttons simultaneously to switch the temperature display between °C and °F.

REMOTE/UNIT IS OFF



## ENERGY SAVING FUNCTION

- In **COOL MODE**, press the MODE and SLEEP buttons simultaneously to turn the Energy-Saving function ON or OFF.

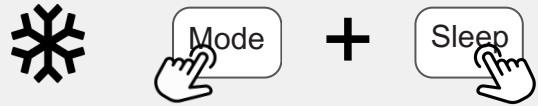

- When activated, "SE" will appear on the remote controller. The air conditioner will automatically adjust the set temperature based on factory settings to achieve optimal energy efficiency.



### While Energy-Saving mode is active:

- Fan speed is fixed to Auto and cannot be adjusted.
- Set temperature cannot be changed.
- Note: Sleep mode and Energy-Saving mode cannot run at the same time.
- If Energy-Saving mode is active and you press the SLEEP button, Energy-Saving mode will be canceled.
- If Sleep mode is active and you enable Energy-Saving mode, Sleep mode will be canceled.

*This function is only available for some models.*

## Remote - Care and Maintenance

To keep your remote control in good working condition, follow these guidelines:

### KEEP IT CLEAN

- Wipe the surface with a soft, dry cloth.
- Avoid using water, alcohol, or harsh chemicals.
- Keep buttons and the battery compartment free of dust and dirt.

### HANDLE WITH CARE

- Do not drop or subject the remote to strong impact.
- Avoid placing it in direct sunlight or near heat sources.

### BATTERY MAINTENANCE

- Replace batteries when the display dims or the remote becomes unresponsive.
- Use only the recommended battery type.
- If it will not be used for an extended period, remove the batteries to prevent leakage and damage.
- Always insert batteries with the correct polarity (+/-).

### AVOID MOISTURE

- Do not expose the remote to water or operate it with wet hands.
- Keep it away from liquids and humid environments.

### REPLACEMENT OF BATTERIES IN REMOTE CONTROLLER

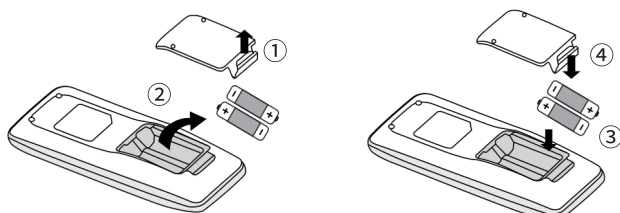

Fig.1

Fig.2

1. Lift the cover along the direction of arrow (as shown in Fig 1①).
2. Take out the original batteries (as shown in Fig 1②).
3. Place two 7# (AAA 1.5V) dry batteries, and make sure the position of “+” polar and “-” polar is correct (as shown in Fig 2③).
4. Reinstall the cover (as shown in Fig 2④).

### NOTE FOR REMOTE

- During operation, point the remote control signal sender at the receiving window on the indoor unit.
- The distance between signal sender and receiving window should be no more than 8m, and there should be no obstacles between them.
- Signal may be interfered easily in the room where there is a fluorescent lamp or wireless telephone; remote controller should be close to indoor unit during operation.
- Replace new batteries of the same model when replacement is required.
- When you don't use the remote controller for a long time, please take out the batteries.
- If the display on remote controller is blurry or there is no display, please replace batteries.

## Remote - Troubleshooting

The following problems are not a malfunction and in most situations will not require repairs.

Issue	Possible Causes	Solution
Remote not responding	Batteries are dead or installed incorrectly	Replace or reinstall batteries correctly
No display on screen	Batteries are exhausted or missing	Insert new batteries
Signal not received by the unit	Remote is too far, or not pointed at unit	Move closer and aim directly at the unit
Interference with signal	Obstacle between remote and indoor unit	Remove obstruction
Some buttons not working	Dust or dirt under buttons	Clean surface and try again
Functions not performing as expected	Wrong mode selected or timer is active	Reset settings or cancel timer
Remote beeps but nothing happens	Indoor unit is off or in error mode	Ensure unit is powered on and not showing error code

Note: If the problem still persists, refer to your air conditioner's user manual or contact Kolin Service Hotline or its Authorized Service Partners for assistance.

## Operation Tips

### OPERATION FOR COMFORT AND ECONOMY

- Do not overcool the room temperature. This is neither good for your health nor energy-efficient.
- Keep blinds or curtains closed. Do not allow direct sunlight to enter the room when the air conditioner is in operation.
- Maintain a uniform room temperature. Adjust the horizontal airflow direction to ensure even temperature distribution throughout the room. Air should not be discharged in the direction of the air intake.
- Ensure that doors and windows are tightly closed. Avoid opening them as much as possible to retain conditioned air within the room.
- Clean the air filter regularly. Blockages in the air filter reduce dehumidifying effects. Clean the air filter at least once every two weeks.
- Ventilate the room occasionally. Since windows are kept closed, it's advisable to open them and ventilate the room periodically. When starting the unit, curtains or windows should be closed to prevent cool air leakage.

### OPERATION FOR SAFETY AND HEALTH

- The plug must be accessible after the appliance is positioned.
- Do not use this appliance in the laundry.
- If the power cord is damaged, it must be replaced to avoid hazards. Contact Kolin Service Hotline or its Authorized Service Partners for replacement.
- Do not pull out the power cord. Damage to the cord may result in serious electric shocks.
- Do not use the air conditioner for purposes other than cooling the room.
- Do not use the air conditioner for other purposes such as drying clothes, preserving food, or cultivating vegetables.
- Do not block the air intake and outlet vents. This causes lowered performance and irregular operation.
- Do not insert sticks or other objects into these vents, as it is dangerous to touch the electric components and the fan.
- Select the most appropriate temperature. Pay attention to adjusting the temperature to suit the conditions. Rooms occupied by infants, the elderly, or the sick should be kept at an appropriate temperature.
- Do not use heating apparatuses in the vicinity. The air conditioner's plastic parts will melt if exposed to excessive heat.
- Avoid exposing the body directly to a continuous, unidirectional airflow for long periods. This is not recommended for health reasons.

### ADDITIONAL NOTE

- Always wait at least 3 minutes before switching the air conditioner on again after you have switched it off during cooling.



# CARE AND MAINTENANCE

## SAFETY PRECAUTION

- Always turn off the air conditioner and main power supply before cleaning to ensure safety.

## Cleaning Unit

Cut off the power before cleaning the unit.

Unplug only after the air conditioner has completely stopped.

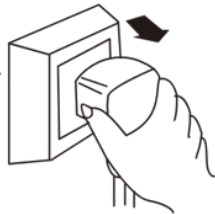

When cleaning the cabinet, use a soft cloth. If the cabinet is very dirty, dampen the cloth in warm water (below 40°C), wring it dry, and then wipe off the dirt.



Dry the cloth by hands before cleaning.

**DO NOT** use gasoline, benzene, solvents, harsh washes, chemical solvents, etc., for cleaning.



**DO NOT** splash water directly into the unit. It contains a micro-computer and circuit board, which must not be drenched with water.



## How to Clean Air Filter

- The air filter located behind the intake grille should be washed at least once every two weeks or more often if needed.

**1** To remove the air intake grille, grasp the tab on the filter and pull to take it out.

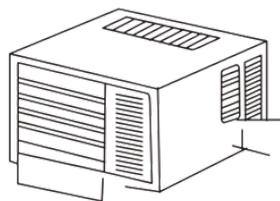

**2** Vacuum the dusty side of the filter to remove light dust.

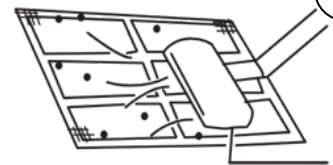

**4** If the filter is very dirty, use a mild household detergent in the wash water.



**3** Wash the filter's cleaner side under gently flowing water to remove accumulated dust and lint.



- Let the filter dry thoroughly before reinstalling it. If necessary, please ask professional personnel to clean it.

## Additional checks

\*Check earth wire

Is it broken or loose?

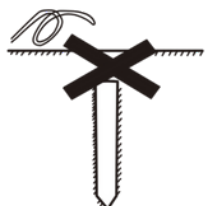

\*Check if the air inlet and outlet of the unit are blocked.

Air lock could result in bad efficiency.



# TROUBLESHOOTING



## SAFETY PRECAUTIONS

If ANY of the following conditions occurs, turn off your unit immediately!

- The power cord is damaged or abnormally warm
- You smell a burning odor
- The unit emits loud or abnormal sounds
- A power fuse blows or the circuit breaker frequently trips
- Water or other objects fall into or out of the unit

**DO NOT ATTEMPT TO FIX THESE YOURSELF! CONTACT A KOLIN SERVICE HOTLINE OR ITS AUTHORIZED SERVICE PARTNERS IMMEDIATELY!**

## Common Issues

The following problems are not a malfunction and in most situations will not require repairs.

Issue	Possible Causes/Troubleshooting
<b>Air conditioner does not operate at all.</b>	<ul style="list-style-type: none"> <li>• Check for a power failure.</li> <li>• Ensure the plug is fully inserted.</li> <li>• Verify the power fuse or switch status.</li> <li>• Confirm the voltage is within acceptable limits.</li> </ul>
<b>Cool efficiency is weak.</b>	<ul style="list-style-type: none"> <li>• Check for any blockage in the air inlet or outlet.</li> <li>• Identify any other heat or cool sources in the room.</li> <li>• Inspect if the air filters are very dirty.</li> <li>• Confirm that the indoor fan speed is not set to LOW.</li> <li>• Note if the room was too hot or too cold when the unit was started.</li> </ul>
<b>Foggy air flows out.</b>	<ul style="list-style-type: none"> <li>• During COOL mode operation, foggy air sometimes flows out of the unit. This occurs because the room's humid air has cooled rapidly.</li> <li>• The unit is operating normally if the indoor outlet emits an odor, as the inlet air may be mixed with the smell of furniture and smoke.</li> </ul>
<b>The air conditioner operation is noisy.</b>	<ul style="list-style-type: none"> <li>• A noise resembling flowing water indicates the sound of freon moving inside the air conditioner unit.</li> <li>• A noise resembling a shower indicates the sound of dehumidifying water being processed inside the air conditioner unit.</li> </ul>
<b>It seems that condensation is leaking from the air conditioner.</b>	<ul style="list-style-type: none"> <li>• Condensation occurs when the airflow from the air conditioner cools the warm room air.</li> </ul>
<b>Air conditioner does not operate for about 3 minutes when restart.</b>	<ul style="list-style-type: none"> <li>• This feature is designed to protect the mechanism.</li> <li>• Wait approximately three minutes for operation to begin.</li> </ul>

### NOTE:

- If you have checked all of the above items and taken the recommended measures but the air conditioner still does not operate properly, stop using the unit immediately and contact Kolin Service Hotline or its Authorized Service Partners. Only qualified service personnel should inspect and repair the unit.

MALFUNCTION CODE	SOLUTION	
E2	Contact Kolin Service Hotline or its Authorized Service Partners for assistance.	
E4		
E5		
E6		
F0		
F0		
F1		
F2		
F3		
F4		
F5		
H1		This indicates a defrosting status.
H3		Contact Kolin Service Hotline or its Authorized Service Partners for assistance.
H4		
H5		
HC		
L9		
LP		
PH		
PL		
U7		

**NOTE:**

- If other malfunction codes appear, please contact the Kolin Service Hotline or its Authorized Service Partners for assistance.

**AFTER SERVICE**

- For any quality concerns or other issues with your air conditioner, please contact the Kolin Service Hotline or its Authorized Service Partners for assistance.

**The design and specifications are subject to change without prior notice for product improvement. Any updates to the manual will be uploaded to the service website, please check for the latest version.**

If you have any concerns, please contact us at the following:

Customer hotline: **(02) 8852-6868**

Text hotline: **+63 917-881-8982**

Email: **service@kolinphil.com.ph**

Also, please like and follow us on social media accounts:

Facebook: kolinphilippines

Instagram: kolinphilippines

Youtube: kolinphilippines

Tiktok: kolinphilippines

Website: [www.kolinphil.com.ph](http://www.kolinphil.com.ph)

**KPI010826**



# Kolin Philippines International, Inc.

## SERVICE CENTERS

BRANCH	ADDRESS	TEL. NO.
Bacolod	Door #A-2 & A-3 UTC Bldg., Alunan St., Brgy. 36, Bacolod City	(034) 466-9145
Cagayan De Oro	Door #3 De Oro Land Bldg., Julio Pacana St., Puntod, Cagayan de Oro City	(088) 557 - 7353
Cebu	Lot 758-B-1, P. Suico St. Upper Tabok, Mandaue City, Cebu	(032) 234 - 1844
Dagupan	Unit #1 107 Caranglaan District, Dagupan City, Pangasinan	(075) 529 - 0587
Davao	Blk 17 Lot 9, Calamansi St., Juna Subd., Matina, Davao City	(082) 272 - 0048
Iloilo	Door# 4,5 & 7, D' Appliance Arcade, South Fundidor, Molo, Iloilo City	(033) 337 - 5914
Pampanga	LRK Commercial Bldg., Jose Abad Ave., Lagundi, Mexico, Pampanga	(045) 455 - 2934

For More air conditioner tips, please like, share and follow us on our social media accounts:

Facebook : kolinphilippines  
Instagram : kolinphilippines  
Youtube : kolinphilippines  
Tiktok : kolinphilippines  
Website : [www.kolinphil.com.ph](http://www.kolinphil.com.ph)

### OFFICE

Kolin Bldg. 1854 Sta. Rita St.,  
Guadalupe Nuevo, Makati City, 1212  
Service Hotline: (632) 8852 - 6868

### PLANT

Blk 3 Lot 5, Main Drive First Cavite  
Industrial Estate, Langkaan 1,  
Dasmariñas City, Cavite  
Tel. No.: (046) 402-0793